



INSTALLATION GUIDELINES

AZEK Deck should be installed using the same good building principals used to install wood or composite decking and in accordance with the local building codes and the installation guidelines included below. AZEK Building Products Inc. claims no liability or responsibility for the improper installation of this product. AZEK Deck may not be suitable for every application and it is the sole responsibility of the installer to be sure that AZEK Deck is fit for the intended use. Since all installations are unique, it is also the installer's responsibility to determine the specific requirements for each Deck application. AZEK Building Products recommends that all designs be reviewed by a licensed architect, engineer or local building official before installation. If you have any questions or need further assistance, please call AZEK Customer Service at 1-877-ASK-AZEK, (877) 275-2935 or visit our website at www.azek.com.

STORAGE

- Store AZEK Deck on a flat and level surface.
- Do not stack bundles over 8 units high.
- When possible, leave factory applied protective wrap on the product to help protect against dirt and debris.
- Use care when handling product with a forklift as forks can easily damage the material.
- If banding is used, use protective corners to prevent indents from the bands.

PREPARATION

Follow these guidelines for best deck installation.

- AZEK Deck is one-sided with the grain side up for the walking surface.
- If using AZEK Deck materials on an existing joist structure, check to make sure all joists are level, structurally sound, and there are no nails or screws protruding.
- Proper joist spacing is required for proper installation.

For correct joist spacing:

- Do not exceed 16" center to center for applications with deck board perpendicular to joists.
- Do not exceed 12" center to center for commercial applications.
- For deck boards on a 45° angle, such as a herringbone pattern, the joists should not exceed 12" center to center.

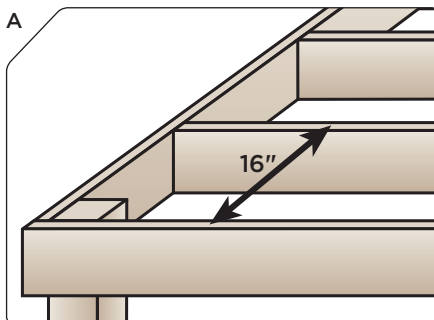

16" BASIC INSTALLATION SUBSTRUCTURE

16" on center maximum joists.
(12" for commercial applications)

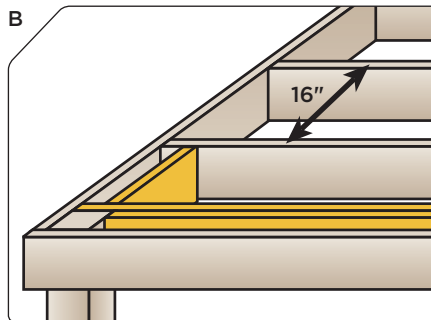

PICTURE FRAME INSTALLATION SUBSTRUCTURE

16" on center maximum joists plus
additional support for the picture
frame structure. (12" for commercial
applications)

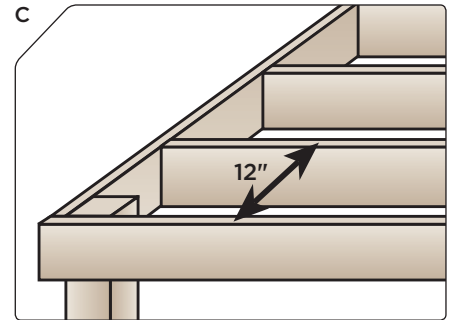

DIAGONAL INSTALLATION SUBSTRUCTURE

12" on center maximum joists.

TOOLS REQUIRED

AZEK Deck materials can be installed using similar tools as you would use to install wood decking or composite decking.

- Corded or cordless driver/screw gun may be used.
- Self-feeding screw guns can be used.
- Miter saw with a fine-toothed, carbide-tipped finish trim blade (12"-60 tooth minimum) works well for cutting.
- As with wood or composite decking, safety glasses should be worn during the entire installation process.

FASTENERS

AZEK Deck materials can be installed using similar fasteners as you would use to install wood or composite decking.

- Due to the durability of AZEK Deck products, a high-quality fastener is recommended that meets the following specifications:
 - Stainless Steel
 - Minimum Screw Size: #7
 - Minimum Length: 2 1/4"
- For salt water coastal applications, we suggest using the above minimum fastener requirements in 316 stainless steel.
- Color-matched stainless steel deck screws are also available. Your AZEK Building Products dealer can assist with more information on these products.
- Hidden Fasteners:
 - The Tiger Claw™ TC-P and Fastenmaster's Cortex™ are two hidden fastener systems commonly used by contractors installing AZEK Deck. Before using other types of hidden fasteners, check with the manufacturer of the fastener and/or AZEK customer service to ensure compatibility.

CARE AND MAINTENANCE

To keep your AZEK Deck looking its best:

- It is recommended that you wash your deck periodically with ordinary household products to remove stains, dirt and debris.
- To remove rust stains, use a household cleaner such as a toilet bowl cleaner.
- Avoid the use of rubber-backed mats, tarps, pool toys, and other non-porous items on the deck for any extended period of time as these items may cause discoloration to the decking surface.
- Some products, such as sunblock and insect repellent, contain chemicals that may alter the surface of AZEK Deck. Check product labels and consult with the manufacturer as to product compatibility with plastic materials, such as AZEK Deck, prior to use on or near AZEK Deck.

For ice removal:

- Most products containing calcium chloride can be used without damage to the deck surface.
- These products may leave a white residue which can be cleaned using the cleaning guidelines above.

(These guidelines may not cover every care and maintenance scenario encountered. For additional questions about care and maintenance, call (877) ASK-AZEK.)

CONSIDERATIONS

Please be aware that excessive heat build on the surface of AZEK products from external sources such as but not limited to fire, or reflection of sunlight can potentially lead to damage. For example, sunlight which may be reflected by low-emissivity (Low-E) glass can potentially lead to damage of exterior building products, including AZEK Deck, Trim, Moulding or Railing products, due to elevation of surface temperatures which far exceed that of normal exposure of the same materials to direct sunlight. Possible damage by such reflected concentrated light may include melting, sagging, warping, distortion, surface discoloration, increased expansion or contraction, and unusual weathering.

EXPANSION AND CONTRACTION

AZEK Deck boards will have minimal expansion and contraction with changes in temperature, unlike wood whose size will fluctuate with moisture changes. The expansion and contraction encountered may result in slight gaps which might be noticed at the ends of boards or in splice joints. Fastening the deck boards according to the Installation Guidelines will help minimize expansion and contraction.

- Expansion and contraction are most significant where extreme temperature change may exist.
- Best practice is to cut and fasten the deck boards as soon after cutting as possible.
- When ambient temperature is above 32°F, install the boards together tightly at splices or miters.
- When ambient temperature is 32°F or below, allow approximately a 1/16" gap on each end of the run.
- Be sure to fasten ends of boards, splices, or abutments to building or structure securely into framing using 2 screws which are positioned within 1/2" of each board end or joint.
- Provide a 1/8" to 1/4" gap between deck boards.

Some area building codes may require double joisting when joining boards end to end. Always check with your local code authority for specific requirements before installation.

STAIR CODE COMPLIANCE

In order to meet the AC 174 Requirement for stair loading, the following method of construction is necessary:

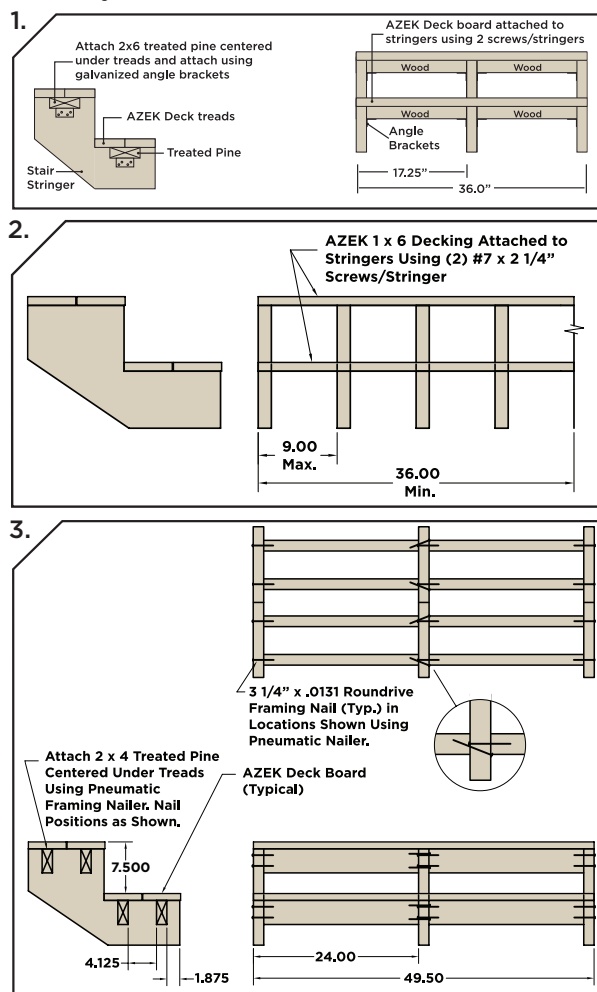

For additional information, visit WWW.AZEK.COM